



SHRINK FIT
BROCHURE
热胀系列手册



SHRINK FIT CHUCK

热胀刀柄



KEY FEATURES

主要特点

High rigidity / More than 3000 times use / 12~23 seconds for normal cutting tools

高刚性 / 3,000次以上热装卸 / 加热12~23秒即可

Naming Rule

命名规则

BBT 40	SR	04	90	T	R	N	
主轴形式	主轴大小	刀柄壁厚	夹持直径	基准面长度	材料	工艺	表面处理
		SR 标准型	SRS 薄壁型	T 特钢	R 整体式	N 有涂层	
		SRC 强力型	SRV 增强型	M 不锈钢	V 焊接式	F 无涂层	

Catalogue

目录

合金钢热胀刀柄 ...B003-B016

不锈钢热胀刀柄 ...B017-B032

热装机B033-B036

Shrink Fit Chuck

热胀刀柄系统

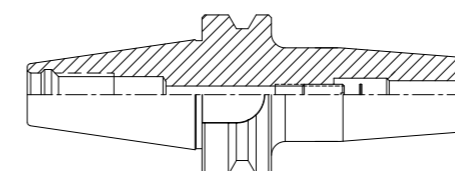

热胀刀柄 Shrink Fit Chuck

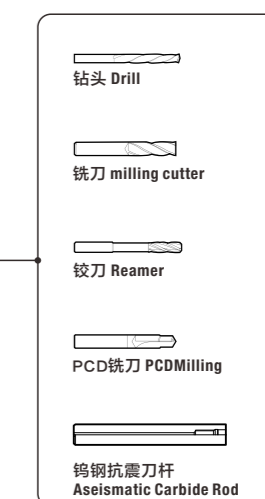

BBT30-SR Shrink Fit Chuck

BBT30-SR 热胀刀柄(标准型) **合金钢**

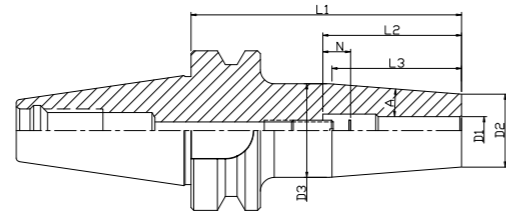

Technical data 技术数据

BBT30-SR

Cat.No 产品型号	D1	D2	D3	L1	L2	L3	N	A	INVENTORY 备货情况
BBT30-SR04-80TRN	4	15	20	80	/	31	/	4.5°	● ▲ ☆
BBT30-SR06-80TRN	6	21	27	80	/	38	/	4.5°	● ▲ ☆
BBT30-SR08-80TRN	8	21	27	80	45	38	18	4.5°	● ▲ ☆
BBT30-SR10-80TRN	10	24	32	80	52	50	20	4.5°	● ▲ ☆
BBT30-SR12-80TRN	12	24	32	80	60	50	28	4.5°	● ▲ ☆
BBT30-SR14-80TRN	14	27	34	80	60	44	24	4.5°	○ ▲ ☆
BBT30-SR16-80TRN	16	27	34	80	65	44	25	4.5°	● ▲ ☆
BBT30-SR18-80TRN	18	33	42	80	65	55	25	4.5°	○ ▲ ☆

注: ● 现货, ▲ 15个工作日, ★ 20个工作日

BBT40-SR Shrink Fit Chuck

BBT40-SR 热胀刀柄(标准型) **合金钢**

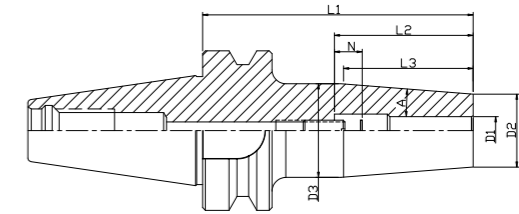

Technical data 技术数据

BBT40-SR

Cat.No 产品型号	D1	D2	D3	L1	L2	L3	N	A	INVENTORY 备货情况
BBT40-SR04-90TRN	4	15	20	90	/	31	/	4.5°	● ▲ ☆
BBT40-SR04-120TRN	4	15	20	120	/	38	/	4.5°	● ▲ ☆
BBT40-SR04-160TRN	4	15	25	160	/	38	/	4.5°	● ▲ ☆
BBT40-SR06-90TRN	6	21	27	90	/	38	/	4.5°	● ▲ ☆
BBT40-SR06-120TRN	6	21	27	120	/	38	/	4.5°	● ▲ ☆
BBT40-SR06-160TRN	6	21	32	160	/	69	/	4.5°	● ▲ ☆
BBT40-SR08-90TRN	8	21	27	90	45	38	18	4.5°	● ▲ ☆
BBT40-SR08-120TRN	8	21	27	120	45	38	18	4.5°	● ▲ ☆
BBT40-SR08-160TRN	8	21	32	160	45	69	18	4.5°	● ▲ ☆
BBT40-SR10-90TRN	10	24	32	90	52	50	20	4.5°	● ▲ ☆
BBT40-SR10-120TRN	10	24	32	120	52	50	20	4.5°	● ▲ ☆
BBT40-SR10-160TRN	10	24	34	160	52	63	20	4.5°	● ▲ ☆
BBT40-SR12-90TRN	12	24	32	90	60	50	28	4.5°	● ▲ ☆
BBT40-SR12-120TRN	12	24	32	120	60	50	28	4.5°	● ▲ ☆
BBT40-SR12-160TRN	12	24	34	160	60	63	28	4.5°	● ▲ ☆
BBT40-SR14-90TRN	14	27	34	90	60	44	24	4.5°	● ▲ ☆
BBT40-SR14-120TRN	14	27	34	120	60	44	24	4.5°	● ▲ ☆
BBT40-SR14-160TRN	14	27	42	160	60	95	24	4.5°	● ▲ ☆
BBT40-SR16-90TRN	16	27	34	90	65	44	25	4.5°	● ▲ ☆
BBT40-SR16-120TRN	16	27	34	120	65	44	25	4.5°	● ▲ ☆
BBT40-SR16-160TRN	16	27	42	160	65	95	25	4.5°	● ▲ ☆
BBT40-SR18-90TRN	18	33	42	90	65	57	25	4.5°	● ▲ ☆
BBT40-SR18-120TRN	18	33	42	120	65	57	25	4.5°	● ▲ ☆
BBT40-SR18-160TRN	18	33	51	160	65	114	25	4.5°	● ▲ ☆
BBT40-SR20-90TRN	20	33	42	90	65	57	25	4.5°	● ▲ ☆
BBT40-SR20-120TRN	20	33	42	120	65	57	25	4.5°	● ▲ ☆
BBT40-SR20-160TRN	20	33	51	160	65	114	25	4.5°	● ▲ ☆

注: ● 现货, ▲ 15个工作日, ★ 20个工作日

BBT50-SR Shrink Fit Chuck

BBT50-SR 热胀刀柄(标准型) **合金钢**

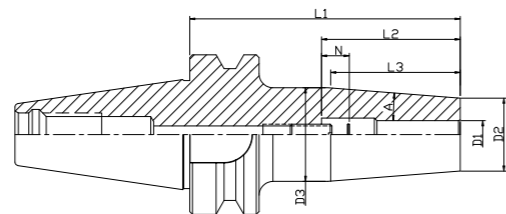

Technical data 技术数据

BBT50-SR

Cat.No 产品型号	D1	D2	D3	L1	L2	L3	N	A	INVENTORY 备货情况
BBT50-SR06-100TRN	6	21	27	100	/	38	/	4.5°	○ ▲ ☆
BBT50-SR06-120TRN	6	21	27	120	/	38	/	4.5°	○ ▲ ☆
BBT50-SR06-160TRN	6	21	32	160	/	69	/	4.5°	○ ▲ ☆
BBT50-SR08-100TRN	8	21	27	100	45	38	18	4.5°	○ ▲ ☆
BBT50-SR08-120TRN	8	21	27	120	45	38	18	4.5°	○ ▲ ☆
BBT50-SR08-160TRN	8	21	32	160	45	69	18	4.5°	○ ▲ ☆
BBT50-SR10-100TRN	10	24	32	100	52	50	20	4.5°	○ ▲ ☆
BBT50-SR10-120TRN	10	24	32	120	52	50	20	4.5°	○ ▲ ☆
BBT50-SR10-160TRN	10	24	34	160	52	63	20	4.5°	○ ▲ ☆
BBT50-SR12-100TRN	12	24	32	100	60	50	28	4.5°	○ ▲ ☆
BBT50-SR12-120TRN	12	24	32	120	60	50	28	4.5°	○ ▲ ☆
BBT50-SR12-160TRN	12	24	34	160	60	63	28	4.5°	○ ▲ ☆
BBT50-SR14-100TRN	14	27	34	100	60	44	24	4.5°	○ ▲ ☆
BBT50-SR14-120TRN	14	27	34	120	60	44	24	4.5°	○ ▲ ☆
BBT50-SR14-160TRN	14	27	42	160	60	95	24	4.5°	○ ▲ ☆
BBT50-SR16-100TRN	16	27	34	100	65	44	25	4.5°	○ ▲ ☆
BBT50-SR16-120TRN	16	27	34	120	65	44	25	4.5°	○ ▲ ☆
BBT50-SR16-160TRN	16	27	42	160	65	95	25	4.5°	○ ▲ ☆
BBT50-SR18-100TRN	18	33	42	100	65	57	25	4.5°	○ ▲ ☆
BBT50-SR18-120TRN	18	33	42	120	65	57	25	4.5°	○ ▲ ☆
BBT50-SR18-160TRN	18	33	51	160	65	114	25	4.5°	○ ▲ ☆
BBT50-SR20-100TRN	20	33	42	100	65	57	25	4.5°	○ ▲ ☆
BBT50-SR20-120TRN	20	33	42	120	65	57	25	4.5°	○ ▲ ☆
BBT50-SR20-160TRN	20	33	51	160	65	57	25	4.5°	○ ▲ ☆

注: ● 现货, ▲ 15个工作日, ★ 20个工作日

HSK32E-SR Shrink Fit Chuck

HSK32E-SR 热胀刀柄(标准型) **合金钢**

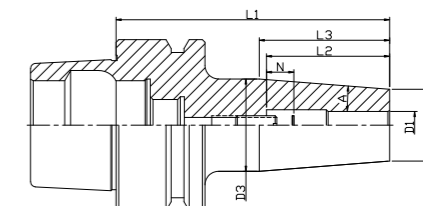

Technical data 技术数据

HSK32E-SR

Cat.No 产品型号	D1	D2	D3	L1	L2	L3	N	A	INVENTORY 备货情况
HSK32E-SR04-60TRN	4	15	20	60	/	31	/	4.5°	● ▲ ☆
HSK32E-SR06-70TRN	6	20	26	70	/	38	/	4.5°	● ▲ ☆
HSK32E-SR08-70TRN	8	20	26	70	45	38	18	4.5°	● ▲ ☆
HSK32E-SR10-70TRN	10	24	29	70	52	31	20	4.5°	● ▲ ☆
HSK32E-SR12-70TRN	12	24	29	70	60	31	28	4.5°	● ▲ ☆

注: ● 现货, ▲ 15个工作日, ★ 20个工作日

HSK40E-SR Shrink Fit Chuck

HSK40E-SR 热胀刀柄(标准型) **合金钢**

Technical data 技术数据

HSK40E-SR

Cat.No 产品型号	D1	D2	D3	L1	L2	L3	N	A	INVENTORY 备货情况
HSK40E-SR04-60TRN	4	15	20	60	/	31	/	4.5°	● ▲ ☆
HSK40E-SR04-80TRN	4	15	20	80	/	31	/	4.5°	● ▲ ☆
HSK40E-SR06-65TRN	6	21	27	65	/	38	/	4.5°	● ▲ ☆
HSK40E-SR06-80TRN	6	21	27	80	/	38	/	4.5°	● ▲ ☆
HSK40E-SR08-65TRN	8	21	27	65	45	38	18	4.5°	● ▲ ☆
HSK40E-SR08-80TRN	8	21	27	80	45	38	18	4.5°	● ▲ ☆
HSK40E-SR10-65TRN	10	24	30	65	52	38	20	4.5°	● ▲ ☆
HSK40E-SR10-80TRN	10	24	32	80	52	50	20	4.5°	● ▲ ☆
HSK40E-SR12-65TRN	12	24	30	65	60	38	28	4.5°	● ▲ ☆
HSK40E-SR12-90TRN	12	24	32	90	60	50	28	4.5°	● ▲ ☆
HSK40E-SR16-90TRN	16	27	34	90	65	44	25	4.5°	○ ▲ ☆

注: ● 现货, ▲ 15个工作日, ★ 20个工作日

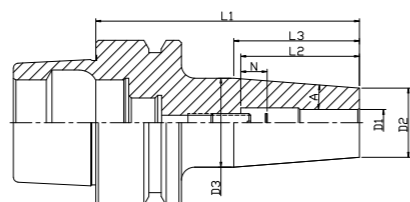

HSK50E-SR Shrink Fit Chuck

HSK50E-SR 热胀刀柄(标准型) **合金钢**

Technical data 技术数据

HSK50E-SR

Cat.No 产品型号	D1	D2	D3	L1	L2	L3	N	A	INVENTORY 备货情况
HSK50E-SR04-80TRN	4	15	20	80	/	31	/	4.5°	● ▲ ☆
HSK50E-SR04-120TRN	4	15	20	120	/	31	/	4.5°	● ▲ ☆
HSK50E-SR06-80TRN	6	21	27	80	/	38	/	4.5°	● ▲ ☆
HSK50E-SR06-120TRN	6	21	27	120	/	38	/	4.5°	● ▲ ☆
HSK50E-SR08-80TRN	8	21	27	80	45	38	18	4.5°	● ▲ ☆
HSK50E-SR08-120TRN	8	21	27	120	45	38	18	4.5°	● ▲ ☆
HSK50E-SR10-85TRN	10	24	32	85	52	50	20	4.5°	● ▲ ☆
HSK50E-SR10-120TRN	10	24	32	120	52	50	20	4.5°	● ▲ ☆
HSK50E-SR12-90TRN	12	24	32	90	60	50	28	4.5°	● ▲ ☆
HSK50E-SR12-120TRN	12	24	32	120	60	50	28	4.5°	● ▲ ☆
HSK50E-SR14-90TRN	14	27	34	90	60	44	24	4.5°	○ ▲ ☆
HSK50E-SR14-120TRN	14	27	34	120	60	44	24	4.5°	○ ▲ ☆
HSK50E-SR16-95TRN	16	27	34	95	65	44	25	4.5°	● ▲ ☆
HSK50E-SR16-120TRN	16	27	34	120	65	44	25	4.5°	● ▲ ☆
HSK50E-SR18-95TRN	18	33	42	95	65	57	25	4.5°	○ ▲ ☆
HSK50E-SR20-100TRN	20	33	42	100	65	57	25	4.5°	● ▲ ☆

注: ● 现货, ▲ 20个工作日, ★ 25个工作日

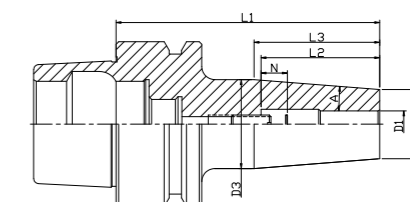

HSK50A-SR Shrink Fit Chuck

HSK50A-SR 热胀刀柄(标准型) **合金钢**

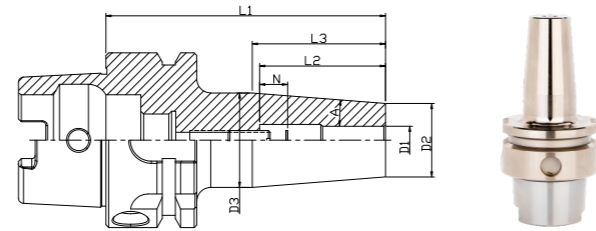

Technical data 技术数据

HSK50A-SR

Cat.No 产品型号	D1	D2	D3	L1	L2	L3	N	A	INVENTORY 备货情况
HSK50A-SR04-80TRN	4	15	20	80	/	31	/	4.5°	● ▲ ☆
HSK50A-SR04-120TRN	4	15	20	120	/	31	/	4.5°	● ▲ ☆
HSK50A-SR04-160TRN	4	15	25	160	/	63	/	4.5°	● ▲ ☆
HSK50A-SR06-80TRN	6	21	27	80	/	38	/	4.5°	● ▲ ☆
HSK50A-SR06-120TRN	6	21	27	120	/	38	/	4.5°	● ▲ ☆
HSK50A-SR06-160TRN	6	21	32	160	/	69	/	4.5°	● ▲ ☆
HSK50A-SR08-80TRN	8	21	27	80	45	38	18	4.5°	● ▲ ☆
HSK50A-SR08-120TRN	8	21	27	120	45	38	18	4.5°	● ▲ ☆
HSK50A-SR08-160TRN	8	21	32	160	45	69	18	4.5°	● ▲ ☆
HSK50A-SR10-85TRN	10	24	32	85	52	50	20	4.5°	● ▲ ☆
HSK50A-SR10-120TRN	10	24	32	120	52	50	20	4.5°	● ▲ ☆
HSK50A-SR10-160TRN	10	24	34	160	52	63	20	4.5°	● ▲ ☆
HSK50A-SR12-90TRN	12	24	32	90	60	50	28	4.5°	● ▲ ☆
HSK50A-SR12-120TRN	12	24	32	120	60	50	28	4.5°	● ▲ ☆
HSK50A-SR12-160TRN	12	24	34	160	60	63	28	4.5°	● ▲ ☆
HSK50A-SR14-90TRN	14	27	34	90	60	44	24	4.5°	● ▲ ☆
HSK50A-SR14-120TRN	14	27	34	120	60	44	24	4.5°	● ▲ ☆
HSK50A-SR14-160TRN	14	27	34	160	60	44	24	4.5°	● ▲ ☆
HSK50A-SR16-95TRN	16	27	34	95	65	44	25	4.5°	● ▲ ☆
HSK50A-SR16-120TRN	16	27	34	120	65	44	25	4.5°	● ▲ ☆
HSK50A-SR16-160TRN	16	27	34	160	65	44	25	4.5°	● ▲ ☆
HSK50A-SR18-95TRN	18	33	42	95	65	57	25	4.5°	● ▲ ☆
HSK50A-SR20-100TRN	20	33	42	100	65	57	25	4.5°	● ▲ ☆

注: ● 现货, ▲ 15个工作日, ★ 20个工作日

HSK63A-SR Shrink Fit Chuck

HSK63A-SR 热胀刀柄(标准型) **合金钢**

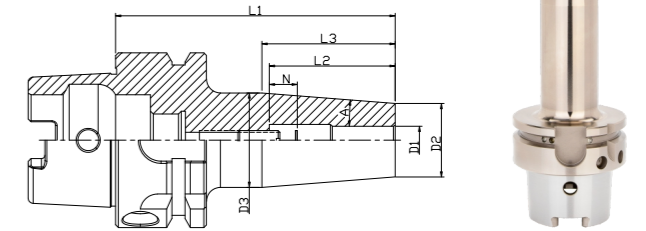

Technical data 技术数据

HSK63A-SR

Cat.No 产品型号	D1	D2	D3	L1	L2	L3	N	A	INVENTORY 备货情况
HSK63A-SR04-80TRN	4	15	20	80	/	31	/	4.5°	● ▲ ☆
HSK63A-SR04-120TRN	4	15	20	120	/	31	/	4.5°	● ▲ ☆
HSK63A-SR04-160TRN	4	15	25	160	/	63	/	4.5°	● ▲ ☆
HSK63A-SR06-80TRN	6	21	27	80	/	38	/	4.5°	● ▲ ☆
HSK63A-SR06-120TRN	6	21	27	120	/	38	/	4.5°	● ▲ ☆
HSK63A-SR06-160TRN	6	21	32	160	/	69	/	4.5°	● ▲ ☆
HSK63A-SR08-80TRN	8	21	27	80	45	38	18	4.5°	● ▲ ☆
HSK63A-SR08-120TRN	8	21	27	120	45	38	18	4.5°	● ▲ ☆
HSK63A-SR08-160TRN	8	21	32	160	45	69	18	4.5°	● ▲ ☆
HSK63A-SR10-85TRN	10	24	32	85	52	50	20	4.5°	● ▲ ☆
HSK63A-SR10-120TRN	10	24	32	120	52	50	20	4.5°	● ▲ ☆
HSK63A-SR10-160TRN	10	24	34	160	52	63	20	4.5°	● ▲ ☆
HSK63A-SR12-90TRN	12	24	32	90	60	50	28	4.5°	● ▲ ☆
HSK63A-SR12-120TRN	12	24	32	120	60	50	28	4.5°	● ▲ ☆
HSK63A-SR12-160TRN	12	24	34	160	60	63	28	4.5°	● ▲ ☆
HSK63A-SR14-90TRN	14	27	34	90	60	44	24	4.5°	● ▲ ☆
HSK63A-SR14-120TRN	14	27	34	120	60	44	24	4.5°	● ▲ ☆
HSK63A-SR14-160TRN	14	27	42	160	60	95	24	4.5°	● ▲ ☆
HSK63A-SR16-95TRN	16	27	34	95	65	44	25	4.5°	● ▲ ☆
HSK63A-SR16-120TRN	16	27	34	120	65	44	25	4.5°	● ▲ ☆
HSK63A-SR16-160TRN	16	27	42	160	65	95	25	4.5°	● ▲ ☆
HSK63A-SR18-95TRN	18	33	42	95	65	57	25	4.5°	● ▲ ☆
HSK63A-SR18-120TRN	18	33	42	120	65	57	25	4.5°	● ▲ ☆
HSK63A-SR18-160TRN	18	33	51	160	65	114	25	4.5°	● ▲ ☆
HSK63A-SR20-100TRN	20	33	42	100	65	57	25	4.5°	● ▲ ☆
HSK63A-SR20-120TRN	20	33	42	120	65	57	25	4.5°	● ▲ ☆
HSK63A-SR20-160TRN	20	33	51	160	65	114	25	4.5°	● ▲ ☆

注: ● 现货, ▲ 20个工作日, ★ 25个工作日

HSK100A-SR Shrink Fit Chuck

HSK100A-SR 热胀刀柄(标准型) **合金钢**

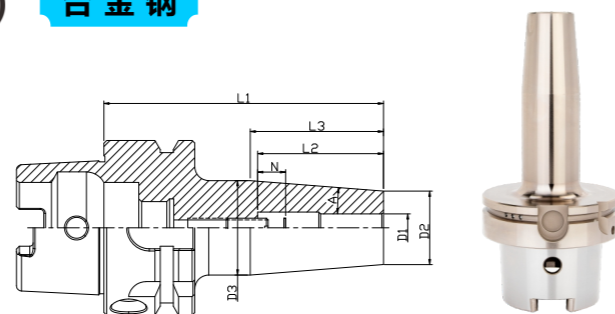

Technical data 技术数据

HSK100A-SR

Cat.No 产品型号	D1	D2	D3	L1	L2	L3	N	A	INVENTORY 备货情况
HSK100A-SR06-85TRN	6	21	27	85	/	38	/	4.5°	○ ▲ ☆
HSK100A-SR06-120TRN	6	21	27	120	/	38	/	4.5°	○ ▲ ☆
HSK100A-SR06-160TRN	6	21	32	160	/	69	/	4.5°	○ ▲ ☆
HSK100A-SR08-85TRN	8	21	27	85	45	38	18	4.5°	○ ▲ ☆
HSK100A-SR08-120TRN	8	21	27	120	45	38	18	4.5°	○ ▲ ☆
HSK100A-SR08-160TRN	8	21	32	160	45	69	18	4.5°	○ ▲ ☆
HSK100A-SR10-90TRN	10	24	32	90	52	50	20	4.5°	○ ▲ ☆
HSK100A-SR10-120TRN	10	24	32	120	52	50	20	4.5°	○ ▲ ☆
HSK100A-SR10-160TRN	10	24	34	160	52	63	20	4.5°	○ ▲ ☆
HSK100A-SR12-95TRN	12	24	32	95	60	50	28	4.5°	○ ▲ ☆
HSK100A-SR12-120TRN	12	24	32	120	60	50	28	4.5°	○ ▲ ☆
HSK100A-SR12-160TRN	12	24	34	160	60	63	28	4.5°	○ ▲ ☆
HSK100A-SR14-95TRN	14	27	34	95	60	44	24	4.5°	○ ▲ ☆
HSK100A-SR14-120TRN	14	27	34	120	60	44	24	4.5°	○ ▲ ☆
HSK100A-SR14-160TRN	14	27	42	160	60	95	24	4.5°	○ ▲ ☆
HSK100A-SR16-100TRN	16	27	34	100	65	44	25	4.5°	○ ▲ ☆
HSK100A-SR16-120TRN	16	27	34	120	65	44	25	4.5°	○ ▲ ☆
HSK100A-SR16-160TRN	16	27	42	160	65	95	25	4.5°	○ ▲ ☆
HSK100A-SR18-100RN	18	33	42	100	65	57	25	4.5°	○ ▲ ☆
HSK100A-SR18-120TRN	18	33	42	120	65	57	25	4.5°	○ ▲ ☆
HSK100A-SR18-160TRN	18	33	51	160	65	114	25	4.5°	○ ▲ ☆
HSK100A-SR20-105TRN	20	33	42	105	65	57	25	4.5°	○ ▲ ☆
HSK100A-SR20-120TRN	20	33	42	120	65	57	25	4.5°	○ ▲ ☆
HSK100A-SR20-160TRN	20	33	51	160	65	114	25	4.5°	○ ▲ ☆

注: ● 现货, ▲ 20个工作日, ★ 25个工作日

HSK63F-SR Shrink Fit Chuck

HSK63F-SR 热胀刀柄(标准型) **合金钢**

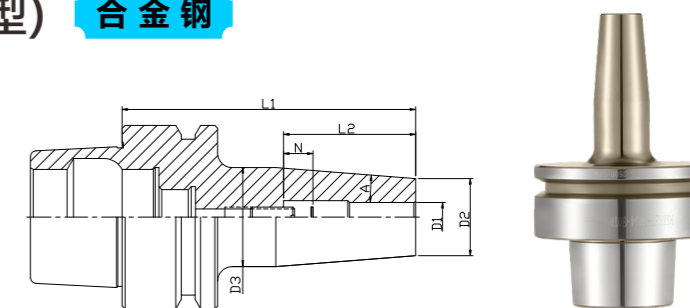

Technical data 技术数据

HSK63F-SR

Cat.No 产品型号	D1	D2	D3	L1	L2	N	A	INVENTORY 备货情况
HSK63F-SR04-80TRN	4	15	20	80	/	/	4.5°	○ ▲ ☆
HSK63F-SR04-120TRN	4	15	20	120	/	/	4.5°	○ ▲ ☆
HSK63F-SR04-160TRN	4	15	27	160	/	/	4.5°	○ ▲ ☆
HSK63F-SR06-90TRN	6	21	27	90	/	/	4.5°	○ ▲ ☆
HSK63F-SR06-120TRN	6	21	32	120	/	/	4.5°	○ ▲ ☆
HSK63F-SR06-160TRN	6	21	27	160	/	/	4.5°	○ ▲ ☆
HSK63F-SR08-90TRN	8	21	27	90	36	9	4.5°	○ ▲ ☆
HSK63F-SR08-120TRN	8	21	27	120	45	18	4.5°	○ ▲ ☆
HSK63F-SR08-160TRN	8	21	32	160	45	18	4.5°	○ ▲ ☆
HSK63F-SR10-90TRN	10	24	32	90	42	10	4.5°	○ ▲ ☆
HSK63F-SR10-120TRN	10	24	32	120	52	20	4.5°	○ ▲ ☆
HSK63F-SR10-160TRN	10	24	34	160	52	20	4.5°	○ ▲ ☆
HSK63F-SR12-95TRN	12	24	32	95	47	15	4.5°	○ ▲ ☆
HSK63F-SR12-120TRN	12	24	32	120	60	28	4.5°	○ ▲ ☆
HSK63F-SR12-160TRN	12	24	34	160	60	28	4.5°	○ ▲ ☆
HSK63F-SR14-95TRN	14	27	34	95	47	11	4.5°	○ ▲ ☆
HSK63F-SR14-120TRN	14	27	34	120	60	36	4.5°	○ ▲ ☆
HSK63F-SR14-160TRN	14	27	42	160	60	36	4.5°	○ ▲ ☆
HSK63F-SR16-95TRN	16	27	34	95	50	10	4.5°	○ ▲ ☆
HSK63F-SR16-120TRN	16	27	34	120	65	25	4.5°	○ ▲ ☆
HSK63F-SR16-160TRN	16	27	42	160	65	25	4.5°	○ ▲ ☆
HSK63F-SR18-95TRN	18	33	42	95	50	10	4.5°	○ ▲ ☆
HSK63F-SR18-120TRN	18	33	42	120	65	25	4.5°	○ ▲ ☆
HSK63F-SR18-160TRN	18	33	51	160	65	25	4.5°	○ ▲ ☆
HSK63F-SR20-100TRN	20	33	42	100	52	12	4.5°	○ ▲ ☆
HSK63F-SR20-120TRN	20	33	42	120	65	15	4.5°	○ ▲ ☆
HSK63F-SR20-160TRN	20	33	51	160	65	15	4.5°	○ ▲ ☆

注: ● 现货, ▲ 15个工作日, ★ 20个工作日

BBT40-SRC Shrink Fit Chuck

BBT40-SRC 热胀刀柄(强力型) **合金钢**

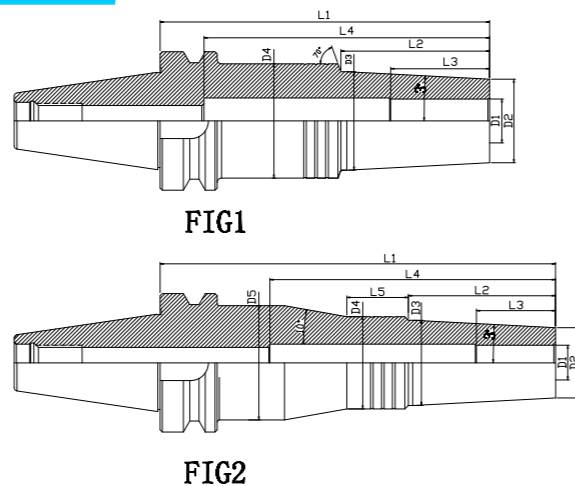

Technical data 技术数据

BBT40-SRC

Cat.No 产品型号	D1	D2	D3	D4	D5	L1	L2	L3	L4	L5	FIG	INVENTORY 备货情况
BBT40-SRC16-120TRN	16	32	39	42	/	120	67	40	95	/	1	● ▲ ☆
BBT40-SRC16-150TRN	16	32	39	42	/	150	67	40	125	/	1	○ ▲ ☆
BBT40-SRC16-180TRN	16	32	39	42	52	180	67	40	125	28	2	○ ▲ ☆
BBT40-SRC20-120TRN	20	38	45	53	/	120	67	45	95	/	1	● ▲ ☆
BBT40-SRC20-150TRN	20	38	45	50	/	150	67	45	125	/	1	○ ▲ ☆
BBT40-SRC20-180TRN	20	38	45	50	/	180	67	45	125	/	1	○ ▲ ☆
BBT40-SRC25-95TRN	25	45	49.4	53	/	95	42	45	70	/	1	● ▲ ☆
BBT40-SRC25-125TRN	25	45	49.4	53	/	125	42	45	100	/	1	○ ▲ ☆
BBT40-SRC25-155TRN	25	45	49.4	53	/	155	42	45	125	/	1	○ ▲ ☆

注: ● 现货, ▲ 15个工作日, ★ 20个工作日

HSK63A-SRC Shrink Fit Chuck

HSK63A-SRC 热胀刀柄(强力型) **合金钢**

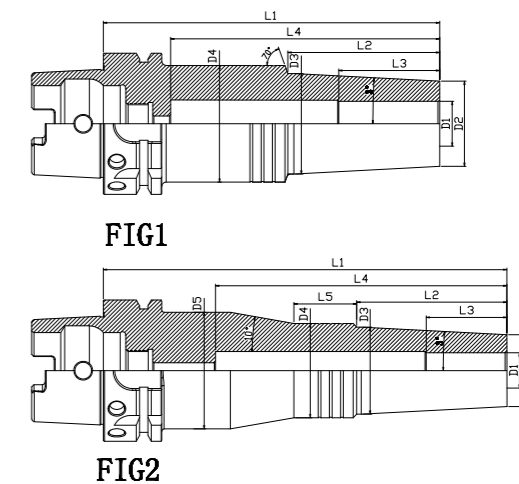

Technical data 技术数据

HSK63A-SRC

Cat.No 产品型号	D1	D2	D3	D4	D5	L1	L2	L3	L4	L5	FIG	INVENTORY 备货情况
HSK63A-SRC16-120TRN	16	32	39	42	/	120	67	40	95	/	1	● ▲ ☆
HSK63A-SRC16-150TRN	16	32	39	42	/	150	67	40	125	/	1	○ ▲ ☆
HSK63A-SRC16-180TRN	16	32	39	42	52	180	67	40	125	28	2	○ ▲ ☆
HSK63A-SRC20-120TRN	20	38	45	53	/	120	67	45	95	/	1	● ▲ ☆
HSK63A-SRC20-150TRN	20	38	45	53	/	150	67	45	125	/	1	○ ▲ ☆
HSK63A-SRC20-180TRN	20	38	45	53	/	180	67	45	125	/	1	○ ▲ ☆
HSK63A-SRC25-95TRN	25	45	49.4	53	/	95	42	45	70	/	1	● ▲ ☆
HSK63A-SRC25-125TRN	25	45	49.4	53	/	125	42	45	100	/	1	○ ▲ ☆
HSK63A-SRC25-155TRN	25	45	49.4	53	/	155	42	45	125	/	1	○ ▲ ☆

注: ● 现货, ▲ 15个工作日, ★ 20个工作日

BBT40-SRV Shrink Fit Chuck

BBT40-SRV 热胀刀柄(曲线增强型) **合金钢**

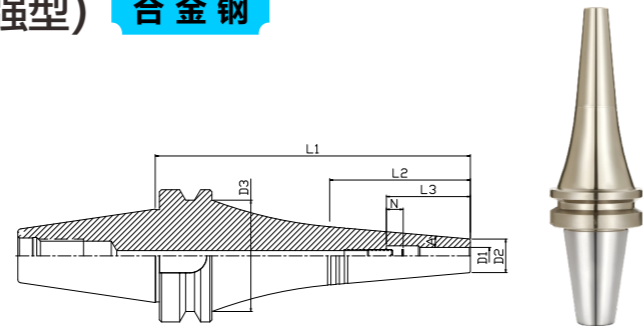

Technical data 技术数据

BBT40-SRV

Cat.No 产品型号	D1	D2	D3	L1	L2	L3	N	A	INVENTORY 备货情况
BBT40-SRV04-150TRN	4	12	53	150	67	/	/	5°	○ ▲ ☆
BBT40-SRV04-180TRN	4	12	53	180	67	/	/	5°	● ▲ ☆
BBT40-SRV04-210TRN	4	12	53	210	67	/	/	5°	○ ▲ ☆
BBT40-SRV06-150TRN	6	14	53	150	67	/	/	5°	○ ▲ ☆
BBT40-SRV06-180TRN	6	14	53	180	67	/	/	5°	● ▲ ☆
BBT40-SRV06-210TRN	6	14	53	210	67	/	/	5°	○ ▲ ☆
BBT40-SRV08-150TRN	8	16	53	150	67	45	18	5°	○ ▲ ☆
BBT40-SRV08-180TRN	8	16	53	180	67	45	18	5°	● ▲ ☆
BBT40-SRV08-210TRN	8	16	53	210	67	45	18	5°	○ ▲ ☆
BBT40-SRV10-150TRN	10	18	53	150	67	52	20	5°	○ ▲ ☆
BBT40-SRV10-180TRN	10	18	53	180	67	52	20	5°	● ▲ ☆
BBT40-SRV10-210TRN	10	18	53	210	67	52	20	5°	○ ▲ ☆
BBT40-SRV12-150TRN	12	20	53	150	67	60	28	5°	○ ▲ ☆
BBT40-SRV12-180TRN	12	20	53	180	67	60	28	5°	● ▲ ☆
BBT40-SRV12-210TRN	12	20	53	210	67	60	28	5°	○ ▲ ☆

注: ● 现货, ▲ 15个工作日, ★ 20个工作日

HSK63A-SRV Shrink Fit Chuck

HSK63A-SRV 热胀刀柄(曲线增强型) **合金钢**

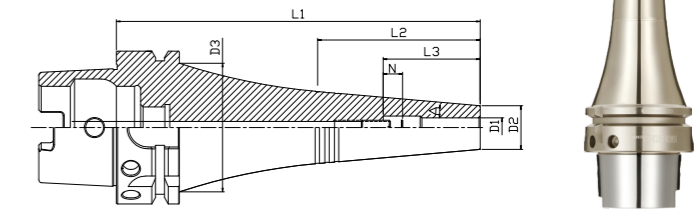

Technical data 技术数据

HSK63A-SRV

Cat.No 产品型号	D1	D2	D3	L1	L2	L3	N	A	INVENTORY 备货情况
HSK63A-SRV04-150TRN	4	12	53	150	67	/	/	5°	○ ▲ ☆
HSK63A-SRV04-180TRN	4	12	53	180	67	/	/	5°	● ▲ ☆
HSK63A-SRV04-210TRN	4	12	53	210	67	/	/	5°	○ ▲ ☆
HSK63A-SRV06-150TRN	6	14	53	150	67	/	/	5°	○ ▲ ☆
HSK63A-SRV06-180TRN	6	14	53	180	67	/	/	5°	● ▲ ☆
HSK63A-SRV06-210TRN	6	14	53	210	67	/	/	5°	○ ▲ ☆
HSK63A-SRV08-150TRN	8	16	53	150	67	45	18	5°	○ ▲ ☆
HSK63A-SRV08-180TRN	8	16	53	180	67	45	18	5°	● ▲ ☆
HSK63A-SRV08-210TRN	8	16	53	210	67	45	18	5°	○ ▲ ☆
HSK63A-SRV10-150TRN	10	18	53	150	67	52	20	5°	○ ▲ ☆
HSK63A-SRV10-180TRN	10	18	53	180	67	52	20	5°	● ▲ ☆
HSK63A-SRV10-210TRN	10	18	53	210	67	52	20	5°	○ ▲ ☆
HSK63A-SRV12-150TRN	12	20	53	150	67	60	28	5°	○ ▲ ☆
HSK63A-SRV12-180TRN	12	20	53	180	67	60	28	5°	● ▲ ☆
HSK63A-SRV12-210TRN	12	20	53	210	67	60	28	5°	○ ▲ ☆

注: ● 现货, ▲ 15个工作日, ★ 20个工作日

SHRINK FIT CHUCK

不锈钢热胀刀柄



KEY FEATURES

主要特点

High rigidity / More than 3000 times use / 22~40 seconds for normal cutting tools
高刚性 / 3,000次以上热装卸 / 加热22-40秒即可

Naming Rule

命名规则

BBT 40	SRS	04	95	M	V	F	
主轴形式	主轴大小	刀柄壁厚	夹持直径	基准面长度	材料	工艺	表面处理
		SRS 薄壁型			T 特钢	R 整体式	N 有涂层
					M 不锈钢	V 焊接式	F 无涂层

Catalogue

目录

- 合金钢热胀刀柄 ...B003-B016
- 不锈钢热胀刀柄 ...B017-B032
- 热装机B033-B036

Clamping Length

夹持长度

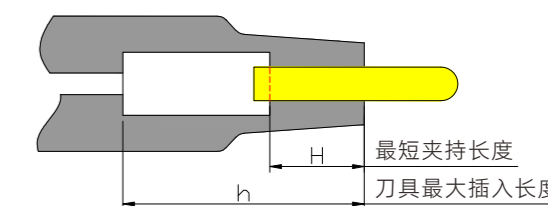

Shrink Fit Chuck

热胀刀柄系统

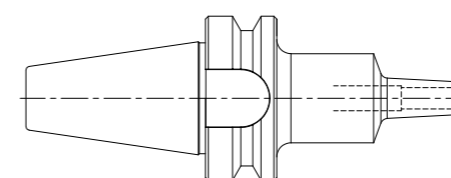

热胀刀柄 Shrink Fit Chuck

- 钻头 Drill
- 铣刀 milling cutter
- 铰刀 Reamer
- PCD铣刀 PCDMilling
- 钨钢抗震刀杆 Aseismatic Carbide Rod

BBT30-SRS-MVF Shrink Fit Chuck

BBT30-SRS-MVF 热胀刀柄 **不锈钢**

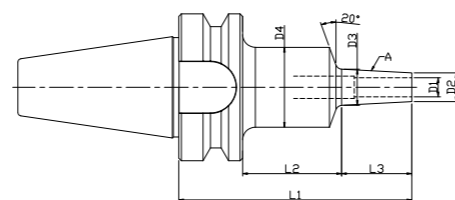

Technical data 技术数据

BBT30-SRS-MVF

Cat.No 产品型号	D1	D2	D3	D4	L1	L2	L3	H	h	A	INVENTORY 备货情况
BBT30-SRS03-75MVF	3	7.5	9.8	25	75	32	22	9	99	3°	● ▲ ☆
BBT30-SRS04-75MVF	4	10	12.3	25	75	32	22	12	99	3°	● ▲ ☆
BBT30-SRS06-75MVF	6	12	14.3	25	75	32	22	18	99	3°	● ▲ ☆
BBT30-SRS08-75MVF	8	14	16.3	25	75	32	22	24	99	3°	● ▲ ☆
BBT30-SRS10-75MVF	10	16	18.3	25	75	32	22	30	99	3°	● ▲ ☆
BBT30-SRS12-75MVF	12	20	22.3	25	75	32	22	30	99	3°	● ▲ ☆

注: ● 现货, ▲ 15个工作日, ★ 20个工作日

BBT40-SRS-MVF Shrink Fit Chuck

BBT40-SRS-MVF 热胀刀柄 **不锈钢**

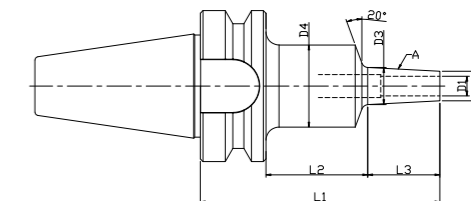

Technical data 技术数据

BBT40-SRS-MVF

Cat.No 产品型号	D1	D2	D3	D4	L1	L2	L3	H	h	A	INVENTORY 备货情况
BBT40-SRS03-95MVF	3	7.5	11.9	25	95	27	42	9	130	3°	● ▲ ☆
BBT40-SRS03-120MVF	3	7.5	14.5	25	120	27	67	9	155	3°	● ▲ ☆
BBT40-SRS03-150MVF	3	7.5	17.7	25	150	27	97	9	185	3°	● ▲ ☆
BBT40-SRS03-180MVF	3	7.5	20.8	36	180	27	127	9	215	3°	● ▲ ☆
BBT40-SRS04-95MVF	4	10	14.4	25	95	27	42	12	130	3°	● ▲ ☆
BBT40-SRS04-120MVF	4	10	17	25	120	27	67	12	155	3°	● ▲ ☆
BBT40-SRS04-150MVF	4	10	20.2	25	150	27	97	12	185	3°	● ▲ ☆
BBT40-SRS04-180MVF	4	10	23.3	32	180	27	127	12	215	3°	● ▲ ☆
BBT40-SRS06-95MVF	6	10	14.4	25	95	27	42	18	130	3°	● ▲ ☆
BBT40-SRS06-120MVF	6	10	17	25	120	27	67	18	155	3°	● ▲ ☆
BBT40-SRS06-150MVF	6	10	20.2	32	150	27	97	18	185	3°	● ▲ ☆
BBT40-SRS06-180MVF	6	10	23.3	32	180	27	127	18	215	3°	● ▲ ☆
BBT40-SRS08-95MVF	8	13	17.4	32	95	27	42	24	130	3°	● ▲ ☆
BBT40-SRS08-120MVF	8	13	20	32	120	27	67	24	155	3°	● ▲ ☆
BBT40-SRS08-150MVF	8	13	23.2	32	150	27	97	24	185	3°	● ▲ ☆
BBT40-SRS08-180MVF	8	13	26.3	32	180	27	127	24	215	3°	● ▲ ☆
BBT40-SRS10-95MVF	10	16	20.4	32	95	27	42	30	130	3°	● ▲ ☆
BBT40-SRS10-120MVF	10	16	23	32	120	27	67	30	155	3°	● ▲ ☆
BBT40-SRS10-150MVF	10	16	26.2	32	150	27	97	30	185	3°	● ▲ ☆
BBT40-SRS10-180MVF	10	16	29.3	42	180	27	127	30	215	3°	● ▲ ☆
BBT40-SRS12-95MVF	12	19	23.4	32	95	27	42	30	130	3°	● ▲ ☆
BBT40-SRS12-120MVF	12	19	26	32	120	27	67	30	155	3°	● ▲ ☆
BBT40-SRS12-150MVF	12	19	29.2	42	150	27	97	30	185	3°	● ▲ ☆
BBT40-SRS12-180MVF	12	19	32.3	42	180	27	127	30	215	3°	● ▲ ☆

注: ● 现货, ▲ 15个工作日, ★ 20个工作日

BT15-SRS-MRF Shrink Fit Chuck

BT15-SRS-MRF 热胀刀柄 **不锈钢**

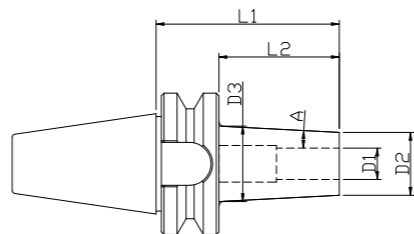

Technical data 技术数据

BT15-SRS-MRF

Cat.No 产品型号	D1	D2	D3	L1	L2	H	h	A	INVENTORY 备货情况
BT15-SRS03-40MRF	3	7.5	10.2	40	28	9	46	3°	○ ▲ ☆
BT15-SRS04-40MRF	4	10	12.7	40	28	12	46	3°	○ ▲ ☆
BT15-SRS06-40MRF	6	12	14.7	40	28	18	46	3°	○ ▲ ☆
BT15-SRS08-40MRF	8	14	16.7	40	28	20	46	3°	○ ▲ ☆
BT15-SRS10-40MRF	10	16	18.7	40	28	20	46	3°	○ ▲ ☆

注: ● 现货, ▲ 15个工作日, ★ 20个工作日

ISO20-SRS-MRF Shrink Fit Chuck

ISO20-SRS-MRF 热胀刀柄 **不锈钢**

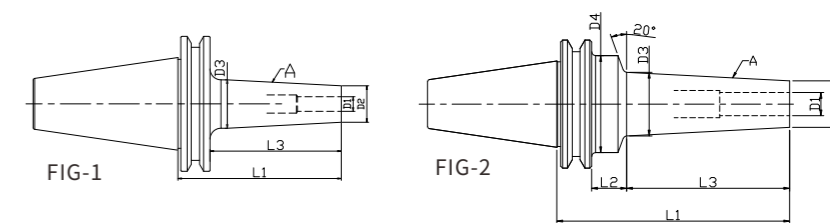

Technical data 技术数据

ISO20-SRS-MRF

Cat.No 产品型号	D1	D2	D3	D4	L1	L2	L3	H	h	A	FIG	INVENTORY 备货情况
ISO20-SRS03-45MRF	3	7.5	10.8	/	45	/	36	9	60	3°	1	○ ▲ ☆
ISO20-SRS03-60MRF	3	7.5	11.8	20	60	9	42	9	75	3°	2	○ ▲ ☆
ISO20-SRS04-45MRF	4	10	13.3	/	45	/	36	12	60	3°	1	● ▲ ☆
ISO20-SRS04-60MRF	4	10	14.3	20	60	9	42	12	75	3°	2	● ▲ ☆
ISO20-SRS06-45MRF	6	12	15.3	/	45	/	36	18	60	3°	1	● ▲ ☆
ISO20-SRS06-60MRF	6	12	16.3	25	60	9	42	18	75	3°	2	● ▲ ☆
ISO20-SRS08-45MRF	8	14	17.3	/	45	/	36	24	60	3°	1	● ▲ ☆
ISO20-SRS08-60MRF	8	14	18.3	25	60	9	42	24	75	3°	2	● ▲ ☆
ISO20-SRS10-55MRF	10	16	20.4	/	55	/	46	30	70	3°	1	○ ▲ ☆
ISO20-SRS12-55MRF	12	18	22.4	/	55	/	46	30	70	3°	1	○ ▲ ☆

注: ● 现货, ▲ 15个工作日, ★ 20个工作日

ISO25-SRS-MRF Shrink Fit Chuck

ISO25-SRS-MRF 热胀刀柄 **不锈钢**

Technical data 技术数据

ISO25-SRS-MRF

Cat.No 产品型号	D1	D2	D3	D4	L1	L2	L3	H	h	A	FIG	INVENTORY 备货情况
ISO25-SRS03-45MRF	3	7.5	10.8	/	45	/	36.2	9	65	3°	1	○▲☆
ISO25-SRS03-70MRF	3	7.5	11.8	20	70	19.2	42	9	90	3°	2	○▲☆
ISO25-SRS04-45MRF	4	10	13.3	/	45	/	36.2	12	65	3°	1	●▲☆
ISO25-SRS04-70MRF	4	10	14.3	20	70	19.2	42	12	90	3°	2	●▲☆
ISO25-SRS06-45MRF	6	12	15.3	/	45	/	36.2	18	65	3°	1	●▲☆
ISO25-SRS06-70MRF	6	12	16.3	25	70	19.2	42	18	90	3°	2	●▲☆
ISO25-SRS08-45MRF	8	14	17.3	/	45	/	36.2	24	65	3°	1	●▲☆
ISO25-SRS08-70MRF	8	14	18.3	25	70	19.2	42	24	90	3°	2	●▲☆
ISO25-SRS10-55MRF	10	16	20.4	/	55	/	46.2	30	75	3°	1	○▲☆
ISO25-SRS12-55MRF	12	18	22.4	/	55	/	46.2	30	75	3°	1	○▲☆

注：●现货，▲15个工作日，★20个工作日

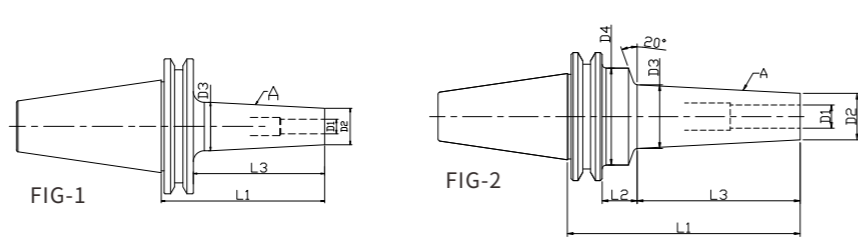

HSK25E-SRS-MRF Shrink Fit Chuck

HSK25E-SRS-MRF 热胀刀柄 **不锈钢**

Technical data 技术数据

HSK25E-SRS-MRF

Cat.No 产品型号	D1	D2	D3	D4	L1	L2	L3	H	h	A	INVENTORY 备货情况
HSK25E-SRS03-35MRF	3	7.5	9.3	18	35	8	17	9	29	3°	●▲☆
HSK25E-SRS04-35MRF	4	10	11.8	18	35	8	17	12	29	3°	●▲☆
HSK25E-SRS04-50MRF	4	10	13.4	18	50	8	32	12	44	3°	●▲☆
HSK25E-SRS06-35MRF	6	12	13.8	18	35	8	17	18	29	3°	●▲☆
HSK25E-SRS06-50MRF	6	12	15.4	18	50	8	32	18	44	3°	●▲☆

注：●现货，▲15个工作日，★20个工作日

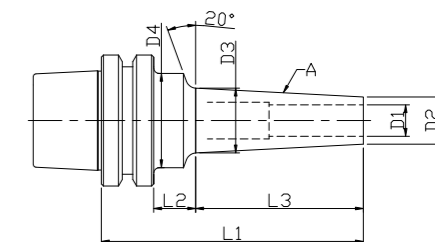

HSK32E-SRS-MRF Shrink Fit Chuck

HSK32E-SRS-MRF 热胀刀柄 **不锈钢**

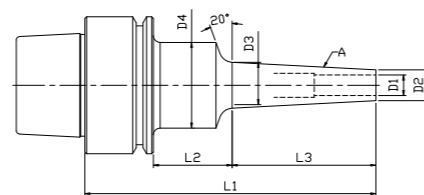

Technical data 技术数据

HSK32E-SRS-MRF

Cat.No 产品型号	D1	D2	D3	D4	L1	L2	L3	H	h	A	INVENTORY 备货情况
HSK32E-SRS03-50MRF	3	7.5	9.8	20	50	8	22	9	42	3°	● ▲ ☆
HSK32E-SRS03-70MRF	3	7.5	11.9	20	70	8	42	9	62	3°	● ▲ ☆
HSK32E-SRS03-85MRF	3	7.5	11.9	25	85	23	42	9	77	3°	● ▲ ☆
HSK32E-SRS04-50MRF	4	10	12.3	20	50	8	22	12	42	3°	● ▲ ☆
HSK32E-SRS04-70MRF	4	10	14.4	20	70	8	42	12	62	3°	● ▲ ☆
HSK32E-SRS04-85MRF	4	10	14.4	25	85	23	42	12	77	3°	● ▲ ☆
HSK32E-SRS06-50MRF	6	12	14.3	26	50	8	22	18	39	3°	● ▲ ☆
HSK32E-SRS06-70MRF	6	12	16.4	26	70	8	42	18	62	3°	● ▲ ☆
HSK32E-SRS06-85MRF	6	12	16.4	25	85	23	42	18	77	3°	● ▲ ☆
HSK32E-SRS08-50MRF	8	14	16.3	26	50	8	22	24	39	3°	● ▲ ☆
HSK32E-SRS08-85MRF	8	14	18.4	25	85	23	42	24	69	3°	● ▲ ☆
HSK32E-SRS10-55MRF	10	16	18.3	26	55	13	22	24	44	3°	● ▲ ☆
HSK32E-SRS12-55MRF	12	20	22.3	26	55	13	22	24	44	3°	● ▲ ☆

注: ● 现货, ▲ 15个工作日, ★ 20个工作日

HSK40E-SRS-MRF Shrink Fit Chuck

HSK40E-SRS-MRF 热胀刀柄 **不锈钢**

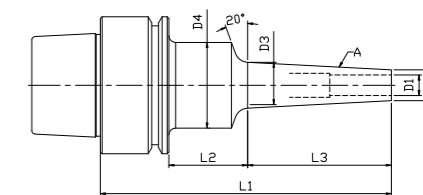

Technical data 技术数据

HSK40E-SRS-MRF

Cat.No 产品型号	D1	D2	D3	D4	L1	L2	L3	H	h	A	INVENTORY 备货情况
HSK40E-SRS03-50MRF	3	7.5	9.8	20	50	8	22	9	42	3°	● ▲ ☆
HSK40E-SRS03-70MRF	3	7.5	11.9	20	70	8	42	9	62	3°	● ▲ ☆
HSK40E-SRS03-85MRF	3	7.5	11.9	25	85	23	42	9	69	3°	● ▲ ☆
HSK40E-SRS04-50MRF	4	10	12.3	20	50	8	22	12	42	3°	● ▲ ☆
HSK40E-SRS04-70MRF	4	10	14.4	20	70	8	42	12	62	3°	● ▲ ☆
HSK40E-SRS04-85MRF	4	10	14.4	25	85	23	42	12	74	3°	● ▲ ☆
HSK40E-SRS06-50MRF	6	12	14.3	26	50	8	22	18	39	3°	● ▲ ☆
HSK40E-SRS06-70MRF	6	12	16.4	26	70	8	42	18	54	3°	● ▲ ☆
HSK40E-SRS06-85MRF	6	12	16.4	25	85	23	42	18	69	3°	● ▲ ☆
HSK40E-SRS08-50MRF	8	14	16.3	26	50	8	22	24	39	3°	● ▲ ☆
HSK40E-SRS08-85MRF	8	14	18.4	25	85	23	42	24	69	3°	● ▲ ☆
HSK40E-SRS08-100MRF	8	14	18.4	25	100	38	42	24	84	3°	● ▲ ☆
HSK40E-SRS10-55MRF	10	16	18.3	26	55	13	22	25	44	3°	● ▲ ☆
HSK40E-SRS10-85MRF	10	16	20.4	25	85	23	42	25	64	3°	● ▲ ☆
HSK40E-SRS10-100MRF	10	16	20.4	25	100	38	42	25	64	3°	● ▲ ☆
HSK40E-SRS12-55MRF	12	20	22.3	30	55	13	22	25	44	3°	● ▲ ☆
HSK40E-SRS12-85MRF	12	20	24.4	32	85	23	42	30	74	3°	● ▲ ☆

注: ● 现货, ▲ 15个工作日, ★ 20个工作日

HSK50E-SRS-MVF Shrink Fit Chuck

HSK50E-SRS-MVF 热胀刀柄 **不锈钢**

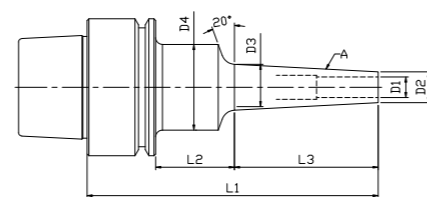

Technical data 技术数据

HSK50E-SRS-MVF

Cat.No 产品型号	D1	D2	D3	D4	L1	L2	L3	H	h	A	INVENTORY 备货情况
HSK50E-SRS03-75MVF	3	7.75	9.8	25	75	27	22	9	61	3°	● ▲ ☆
HSK50E-SRS03-95MVF	3	7.5	11.9	25	95	27	42	9	81	3°	● ▲ ☆
HSK50E-SRS03-120MVF	3	7.5	14.5	25	120	27	67	9	106	3°	● ▲ ☆
HSK50E-SRS03-150MVF	3	7.5	17.7	25	150	27	97	9	136	3°	● ▲ ☆
HSK50E-SRS04-75MVF	4	10	12.3	25	75	27	22	12	61	3°	● ▲ ☆
HSK50E-SRS04-95MVF	4	10	14.4	25	95	27	42	12	81	3°	● ▲ ☆
HSK50E-SRS04-120MVF	4	10	17	25	120	27	67	12	106	3°	● ▲ ☆
HSK50E-SRS04-150MVF	4	10	20.2	32	150	27	97	12	135	3°	● ▲ ☆
HSK50E-SRS06-75MVF	6	12	14.3	25	75	27	22	18	61	3°	● ▲ ☆
HSK50E-SRS06-95MVF	6	12	16.4	25	95	27	42	18	81	3°	● ▲ ☆
HSK50E-SRS06-120MVF	6	12	19	25	120	27	67	18	106	3°	● ▲ ☆
HSK50E-SRS06-150MVF	6	12	22.2	32	150	27	97	18	135	3°	● ▲ ☆
HSK50E-SRS08-95MVF	8	13	17.4	32	95	27	42	24	81	3°	● ▲ ☆
HSK50E-SRS08-120MVF	8	13	20	32	120	27	67	24	105	3°	● ▲ ☆
HSK50E-SRS08-150MVF	8	13	23.2	32	150	27	97	24	132	3°	● ▲ ☆
HSK50E-SRS10-95MVF	10	16	20.4	32	95	27	42	30	81	3°	● ▲ ☆
HSK50E-SRS10-120MVF	10	16	23	32	120	27	67	30	105	3°	● ▲ ☆
HSK50E-SRS10-150MVF	10	16	26.2	32	150	27	97	30	132	3°	● ▲ ☆
HSK50E-SRS12-95MVF	12	19	23.4	32	95	27	42	30	80	3°	● ▲ ☆
HSK50E-SRS12-120MVF	12	19	26	32	120	27	67	30	105	3°	● ▲ ☆
HSK50E-SRS12-150MVF	12	19	29.2	32	150	27	97	30	135	3°	● ▲ ☆

注: ● 现货, ▲ 15个工作日, ★ 20个工作日

HSK50A-SRS-MVF Shrink Fit Chuck

HSK50A-SRS-MVF 热胀刀柄 **不锈钢**

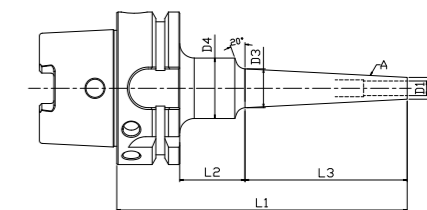

Technical data 技术数据

HSK50A-SRS-MVF

Cat.No 产品型号	D1	D2	D3	D4	L1	L2	L3	H	h	A	INVENTORY 备货情况
HSK50A-SRS03-75MVF	3	7.75	9.8	25	75	27	22	9	61	3°	● ▲ ☆
HSK50A-SRS03-95MVF	3	7.5	11.9	25	95	27	42	9	81	3°	● ▲ ☆
HSK50A-SRS03-120MVF	3	7.5	14.5	25	120	27	67	9	106	3°	● ▲ ☆
HSK50A-SRS03-150MVF	3	7.5	17.7	25	150	27	97	9	136	3°	● ▲ ☆
HSK50A-SRS04-75MVF	4	10	12.3	25	75	27	22	12	61	3°	● ▲ ☆
HSK50A-SRS04-95MVF	4	10	14.4	25	95	27	42	12	81	3°	● ▲ ☆
HSK50A-SRS04-120MVF	4	10	17	25	120	27	67	12	106	3°	● ▲ ☆
HSK50A-SRS04-150MVF	4	10	20.2	32	150	27	97	12	135	3°	● ▲ ☆
HSK50A-SRS06-75MVF	6	12	14.3	25	75	27	22	18	61	3°	● ▲ ☆
HSK50A-SRS06-95MVF	6	12	16.4	25	95	27	42	18	81	3°	● ▲ ☆
HSK50A-SRS06-120MVF	6	12	19	25	120	27	67	18	106	3°	● ▲ ☆
HSK50A-SRS06-150MVF	6	12	22.2	32	150	27	97	18	135	3°	● ▲ ☆
HSK50A-SRS08-95MVF	8	13	17.4	32	95	27	42	24	81	3°	● ▲ ☆
HSK50A-SRS08-120MVF	8	13	20	32	120	27	67	24	105	3°	● ▲ ☆
HSK50A-SRS08-150MVF	8	13	23.2	32	150	27	97	24	132	3°	● ▲ ☆
HSK50A-SRS10-95MVF	10	16	20.4	32	95	27	42	30	81	3°	● ▲ ☆
HSK50A-SRS10-120MVF	10	16	23	32	120	27	67	30	105	3°	● ▲ ☆
HSK50A-SRS10-150MVF	10	16	26.2	32	150	27	97	30	132	3°	● ▲ ☆
HSK50A-SRS12-95MVF	12	19	23.4	32	95	27	42	30	80	3°	● ▲ ☆
HSK50A-SRS12-120MVF	12	19	26	32	120	27	67	30	105	3°	● ▲ ☆
HSK50A-SRS12-150MVF	12	19	29.2	32	150	27	97	30	135	3°	● ▲ ☆

注: ● 现货, ▲ 15个工作日, ★ 20个工作日

HSK63A-SRS-MVF Shrink Fit Chuck

HSK63A-SRS-MVF 热胀刀柄 **不锈钢**

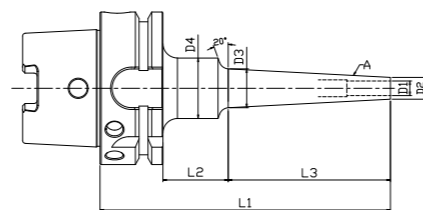

Technical data 技术数据

HSK63A-SRS-MVF

Cat.No 产品型号	D1	D2	D3	D4	L1	L2	L3	H	h	A	INVENTORY 备货情况
HSK63A-SRS03-95MVF	3	7.5	11.9	25	95	27	42	9	70	3°	●▲☆
HSK63A-SRS03-120MVF	3	7.5	14.5	36	120	27	67	9	95	3°	●▲☆
HSK63A-SRS03-150MVF	3	7.5	17.7	25	150	27	97	9	125	3°	●▲☆
HSK63A-SRS03-180MVF	3	7.5	20.8	26	180	27	127	9	155	3°	●▲☆
HSK63A-SRS04-95MVF	4	10	14.4	25	95	27	42	12	70	3°	●▲☆
HSK63A-SRS04-120MVF	4	10	17	25	120	27	67	12	95	3°	●▲☆
HSK63A-SRS04-150MVF	4	10	20.2	25	150	27	97	12	124	3°	●▲☆
HSK63A-SRS04-180MVF	4	10	23.3	32	180	27	127	12	154	3°	●▲☆
HSK63A-SRS06-95MVF	6	10	14.4	25	95	27	42	18	70	3°	●▲☆
HSK63A-SRS06-120MVF	6	10	17	25	120	27	67	18	95	3°	●▲☆
HSK63A-SRS06-150MVF	6	10	20.2	32	150	27	97	18	124	3°	●▲☆
HSK63A-SRS06-180MVF	6	10	23.3	32	180	27	127	18	154	3°	●▲☆
HSK63A-SRS08-95MVF	8	13	17.4	32	95	27	42	24	69	3°	●▲☆
HSK63A-SRS08-120MVF	8	13	20	32	120	27	67	24	94	3°	●▲☆
HSK63A-SRS08-150MVF	8	13	23.2	32	150	27	97	24	124	3°	●▲☆
HSK63A-SRS08-180MVF	8	13	26.3	32	180	27	127	24	154	3°	●▲☆
HSK63A-SRS10-95MVF	10	16	20.4	32	95	27	42	30	69	3°	●▲☆
HSK63A-SRS10-120MVF	10	16	23	32	120	27	67	30	94	3°	●▲☆
HSK63A-SRS10-150MVF	10	16	26.2	32	150	27	97	30	124	3°	●▲☆
HSK63A-SRS10-180MVF	10	16	29.3	32	180	27	127	30	155	3°	●▲☆
HSK63A-SRS12-95MVF	12	19	23.4	32	95	27	42	30	69	3°	●▲☆
HSK63A-SRS12-120MVF	12	19	26	32	120	27	67	30	94	3°	●▲☆
HSK63A-SRS12-150MVF	12	19	29.2	42	150	27	97	30	125	3°	●▲☆
HSK63A-SRS12-180MVF	12	19	32.3	42	180	27	127	30	155	3°	●▲☆

注：●现货，▲15个工作日，★20个工作日

HSK63F-SRS-MVF Shrink Fit Chuck

HSK63F-SRS-MVF 热胀刀柄 **不锈钢**

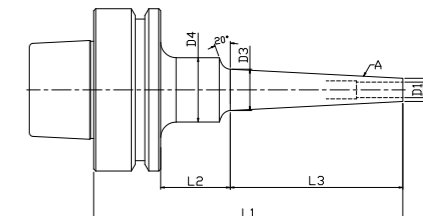

Technical data 技术数据

HSK63F-SRS-MVF

Cat.No 产品型号	D1	D2	D3	D4	L1	L2	L3	H	h	A	INVENTORY 备货情况
HSK63F-SRS03-75MVF	3	7.5	9.8	25	75	27	22	9	54	3°	○▲☆
HSK63F-SRS03-95MVF	3	7.5	11.9	25	95	27	42	9	78	3°	○▲☆
HSK63F-SRS04-75MVF	4	10	12.3	25	75	27	22	12	58	3°	○▲☆
HSK63F-SRS04-95MVF	4	10	14.4	25	95	27	42	12	78	3°	○▲☆
HSK63F-SRS06-75MVF	6	12	14.3	25	75	27	22	18	58	3°	○▲☆
HSK63F-SRS06-95MVF	6	12	16.4	25	95	27	42	18	78	3°	○▲☆
HSK63F-SRS08-75MVF	8	14	16.3	25	75	27	22	24	58	3°	○▲☆
HSK63F-SRS08-95MVF	8	14	18.4	25	95	27	42	24	78	3°	○▲☆
HSK63F-SRS10-75MVF	10	16	18.3	25	75	27	22	30	54	3°	○▲☆
HSK63F-SRS10-95MVF	10	16	20.4	32	95	27	42	30	74	3°	○▲☆
HSK63F-SRS12-75MVF	12	20	22.3	25	75	27	22	30	54	3°	○▲☆
HSK63F-SRS12-95MVF	12	19	23.4	32	95	27	42	30	74	3°	○▲☆

注：●现货，▲15个工作日，★20个工作日

BBT40-SP Shrink Fit Chuck

BBT40-SP 模块化热胀刀柄 **合金钢**

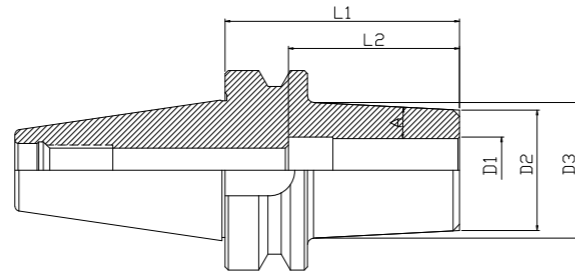

Technical data 技术数据

BBT40-SP

Cat.No 产品型号	D1	D2	D3	L1	L2	A	INVENTORY 备货情况
BBT40-SP20-90TRN	20	38	44	90	50	3°	● ▲ ☆
BBT40-SP20-135TRN	20	38	48	135	50	3°	● ▲ ☆

注: ● 现货, ▲ 15个工作日, ★ 20个工作日

HSK63A-SP Shrink Fit Chuck

HSK63A-SP 模块化热胀刀柄 **合金钢**

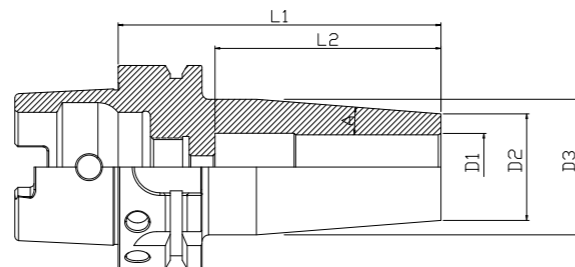

HSK63A-SP

Cat.No 产品型号	D1	D2	D3	L1	L2	A	INVENTORY 备货情况
HSK63A-SP20-90TRN	20	38	44	90	50	3°	● ▲ ☆
HSK63A-SP20-135TRN	20	38	48	135	50	3°	● ▲ ☆

注: ● 现货, ▲ 15个工作日, ★ 20个工作日

SP-SRS Shrink Fit Chuck

SP-SRS 模块化热胀刀杆 **不锈钢**

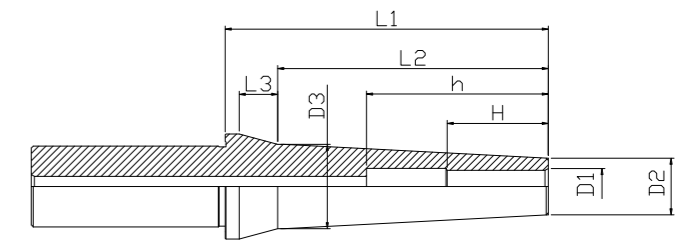

Technical data 技术数据

SP-SRS

Cat.No 产品型号	D1	D2	D3	L1	L2	L3	H	h	INVENTORY 备货情况
SP20-SRS03-55MRF	3	7.5	12	55	42	9.5	10	/	○ ▲ ☆
SP20-SRS03-80MRF	3	7.5	14.6	80	67	9.5	10	/	● ▲ ☆
SP20-SRS04-55MRF	4	10	14.5	55	42	9.5	12	/	○ ▲ ☆
SP20-SRS04-80MRF	4	10	17.1	80	67	9.5	12	/	○ ▲ ☆
SP20-SRS04-110MRF	4	10	20	110	97	9.5	12	/	● ▲ ☆
SP20-SRS06-55MRF	6	12	16.5	55	42	9.5	18	/	○ ▲ ☆
SP20-SRS06-80MRF	6	12	19.1	80	67	9.5	18	/	○ ▲ ☆
SP20-SRS06-110MRF	6	12	22	110	97	9.5	18	/	● ▲ ☆
SP20-SRS08-55MRF	8	14	18.5	55	42	9.5	25	45	○ ▲ ☆
SP20-SRS08-80MRF	8	14	21.1	80	67	9.5	25	45	○ ▲ ☆
SP20-SRS08-110MRF	8	14	24	110	97	9.5	25	45	● ▲ ☆
SP20-SRS10-55MRF	10	16	20.5	55	42	9.5	30	52	○ ▲ ☆
SP20-SRS10-80MRF	10	16	23.1	80	67	9.5	30	52	○ ▲ ☆
SP20-SRS12-55MRF	12	20	24	55	42	9.5	36	60	● ▲ ☆
SP20-SRS12-80MRF	12	20	25.5	80	/	/	36	60	○ ▲ ☆

注: ● 现货, ▲ 15个工作日, ★ 20个工作日

Shrink Fit Heating Machine

智能风冷热装机

- 操作简便,性价比高;
- AC 220V~240V电压;
- 机身轻便,占地空间小;
- 可烧结柄径为 $\phi 3-\phi 20$ 。

Easy to operate, highly cost-effective;
AC 220V~240V voltage;
The body is light and covers a small space;
Sintered handle diameter is $\phi 3-\phi 20$.



H535 Plus
H550 Plus

Heating Machine Data 技术数据

Cat.No 机器型号	HEATING RANGE 加热范围	SIZE 尺寸	MAX D 刀柄最大外径	SUPPLY 电源	CURRENT 电流	WEIGHT 重量	INVENTORY 备货情况
H535 Plus	3-12mm	540x400x780mm	30mm	AC220	16A	25KG	● ▲ ☆
H550 Plus	3-20mm	540x400x780mm	45mm	AC220	16A	25KG	● ▲ ☆

注: ● 现货, ▲ 15个工作日, ★ 20个工作日

Options 配件

TYPE 类型	MODEL 型号	D	PHOTO 产品图片
定位卡簧 Clamp Spring	HSB-D	4 / 6 / 8 / 10 / 12 标配 3 / 16 / 20 选配	
隔热手套 Oven Glove	HP-GT 标配		
转换套 Conversion Sleeve 任选其一标配	SH-BT30 选配 SH-BT40 选配 SH-HSK25 选配 SH-HSK32 选配 SH-HSK40 选配 SH-HSK50 选配 SH-HSK63 选配 SH-ISO20 选配 SH-ISO25 选配 SH-YCG 选配		

Shrink Fit Heating Machine

智能风冷热装机【快换线圈】

- 快换线圈, 智能感应切换系统;
- AC 220V电压;
- 机身轻便,占地空间小;
- 可烧结柄径为 $\phi 3-\phi 32$ 。

Quick change coil, intelligent induction switching system;
AC 380V voltage;
The body is light and covers a small space;
Sintered handle diameter is $\phi 3-\phi 32$.

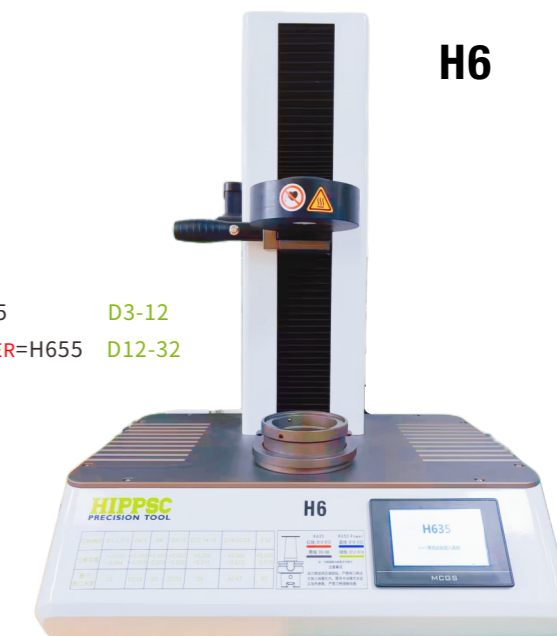

H6

Heating Machine Data 技术数据

Cat.No 机器型号	HEATING RANGE 加热范围	SIZE 尺寸	MAX D 刀柄最大外径	SUPPLY 电源	CURRENT 电流	WEIGHT 重量	INVENTORY 备货情况
H635	3-12mm	540x400x780mm	30mm	AC220	16A	25KG	● ▲ ☆

注: ● 现货, ▲ 15个工作日, ★ 20个工作日

Options 配件

TYPE 类型	MODEL 型号	D	HEATING RANGE 加热范围	PHOTO 产品图片
快换线圈 Quick change coil	K655 Power 选配	55	D12-32	
定位卡簧 Clamp Spring	HSB-D 选配	4 / 6 / 8 / 10 / 12 3 / 16 / 20		
隔热手套 Oven Glove	HP-GT 标配			
隔热环 Insulation Ring	G55SR1216 选配 G55SR1825 选配 G55SR2532 选配		适用于厚壁型、强力型	
转换套 Conversion Sleeve	SH-BT30 SH-BT40 选配 SH-HSK25 SH-HSK32 选配 SH-HSK40 SH-HSK50 选配 SH-HSK63 SH-YCG 选配 SH-ISO20 SH-ISO25 选配			

Shrink Fit Heating Machine

全自动智能水冷热装机【快换线圈】

AUTO F15

- 全自动智能加热水冷一体设计；
- 合金钢材、不锈钢材一机通烧；
- 精准加热千次不发黑，有效减少积碳，保证夹持精度
- 有效延长刀柄使用寿命；
- 机头自带冷却模块，可二十四小时连续工作；
- 2秒加热，15秒冷却；
- 操作更安全、更智能。

- Fully automatic intelligent heating and water cooling integrated design;
- Alloy steel and stainless steel are all fired in one machine;
- Accurate heating for thousands of times without blackening, effectively reduce carbon deposition and ensure clamping accuracy
- Effectively prolong the service life of the tool handle;
- The head is equipped with cooling module, which can work continuously for 24 hours;
- Heating for 2 seconds and cooling for 15 seconds;
- Safer and smarter operation.



Technical data 技术数据

Cat.No 线圈型号	HEATING RANGE 加热范围	MAX D 刀柄最大外径	SUPPLY 电压	CURRENT 电流	WEIGHT 重量	INVENTORY 备货情况
F1535	3-12mm	30mm	380V	32A	155KG	● ▲ ☆

注：● 现货，▲ 15个工作日，★ 20个工作日

Options 选配件

TYPE 类型	MODEL 型号	D	HEATING RANGE 加热范围	PHOTO 产品图片
快换线圈 Quick change coil	K1555 Power 选配	55	D12-32	
	K1568 Power 选配	68	D20-32 强力型	
隔热手套 Oven Glove	HP-GT 选配			
转换套 Conversion Sleeve	FAX-BT50 选配 FAX-BT40/BT30 选配 FAX-HSK100/HSK63/HSK50/HSK40 选配			
隔热环 Insulation Ring	G35SR0305 选配 G55SR1825 选配 G35SR0612 选配 G55SR2532 选配 G55SR1216 选配 G68SRC2532 选配		适用于厚壁型、强力型	
刀长限位器 Position Limiter	DCXW3-6 选配 DCXW6.1-12 选配			